

SMD Type 1500 W

■ Features

1. For surface mounted applications
2. RoHS compliant and halogen-free
3. Reliable low cost construction utilizing molded plastic technique
4. Glass passivated chip junction
5. Both bi-directional and uni-directional devices are available
6. Fast response time
7. Low leakage
8. Excellent clamping capability
9. 1500W peak pulse power capability with a 10/1000 μ s waveform, repetitive rate (duty cycle): 0.01%
10. High reliability application and automotive grade AEC Q101 qualified



■ Recommended Applications

1. Telecommunication
2. Computer
3. Industrial device
4. Consumer electronic device
5. Automotive

■ Mechanical Data

1. Case: DO-214AB (SMC), molded plastic meets UL flammability rating 94V-0
2. Terminal: Matte Tin-plated leads, solderable per MIL-STD-750, Method 2026
3. Polarity: The band denotes cathode (Note: no polarity indicator for bi-directional devices)

■ Part Number Code

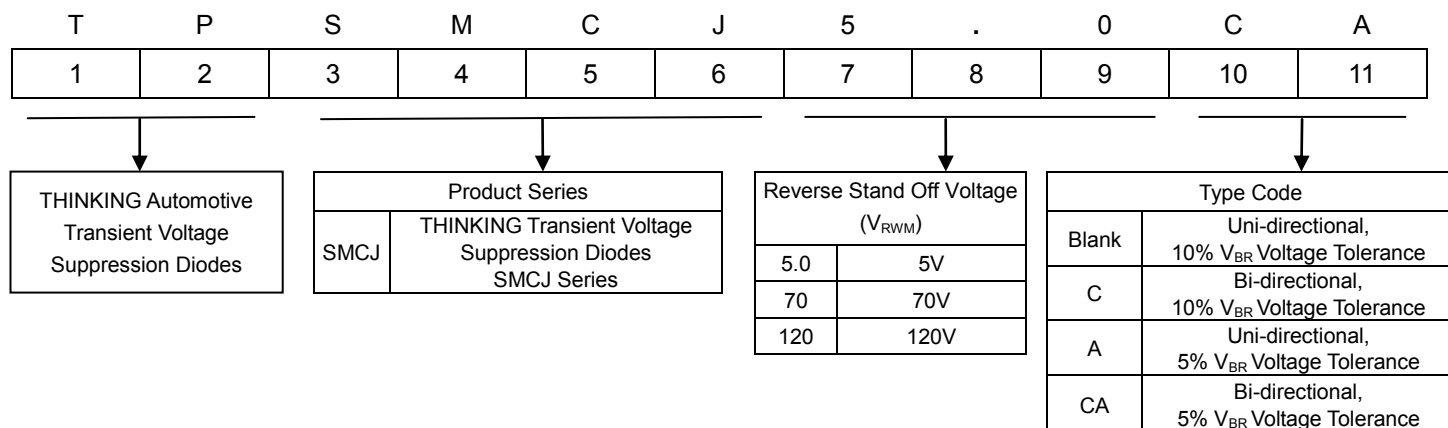

Transient Voltage Suppression Diodes: TPSMCJ Series

SMD Type 1500 W



Structures and Dimensions

SMC-DO214AB

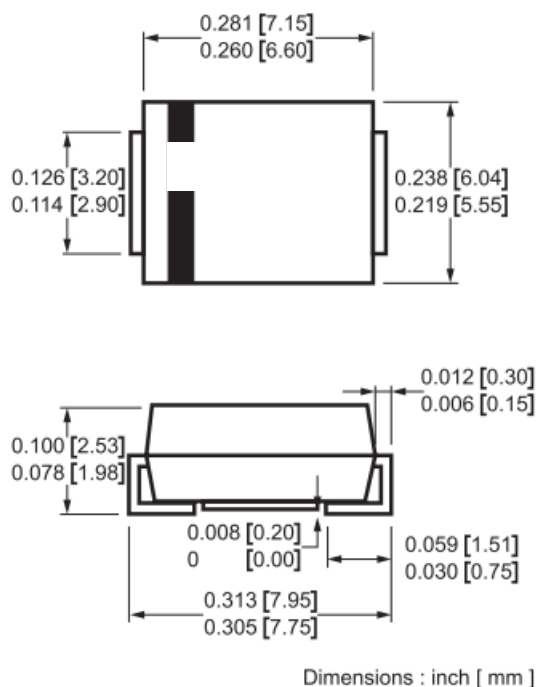

Maximum Rating ($T_A=25^\circ\text{C}$ unless otherwise noted)

Parameter	Symbol	Value	Unit
Peak pulse power dissipation at $T_A=25^\circ\text{C}$ by 10/1000 μs waveform (Note1).	P_{PPM}	1500	W
Peak pulse current of on 10/1000 μs waveform (Note1)	I_{PPM}	See Table	A
Peak forward surge current, 8.3ms single half sine wave on rated load (Note 2)	I_{FSM}	200	A
Power dissipation on infinite heatsink at $T_L=75^\circ\text{C}$	P_{Dj}	6.5	W
Operating junction and storage temperature range	T_J, T_{STG}	-55~+150	$^\circ\text{C}$

Note: 1. Please refer to Fig. 5 for non-repetitive current pulse, and Fig. 1 for derated above $T_A = 25^\circ\text{C}$

2. 8.3ms single half sine-wave, or square wave that has a maximum of 4 pulses per minute.

Transient Voltage Suppression Diodes: TPSMCJ Series



SMD Type 1500 W

■ Electrical Characteristics ($T_A=25^\circ\text{C}$ unless otherwise noted)

Part No. (Uni)	Part No. (Bi)	Reverse Stand off Voltage	Breakage Voltage VBR @ IT		Test Current IT(mA)	Maximum Clamping Voltage VC @ Ipp	Maximum Peak Pulse Current Ipp(A)	Maximum Reverse Leakage IR @VRWM	Marking Code	
			VRWM (V)	Min(V)					Max(V)	UNI
TPSMCJ10A	TPSMCJ10CA	10	11.1	12.3	1	17	88.24	5	GDXA	BDXA
TPSMCJ11A	TPSMCJ11CA	11	12.2	13.5	1	18.2	82.42	1	GDZA	BDZA
TPSMCJ12A	TPSMCJ12CA	12	13.3	14.7	1	19.9	75.38	1	GEEA	BEEA
TPSMCJ13A	TPSMCJ13CA	13	14.4	15.9	1	21.5	69.77	1	GEGA	BEGA
TPSMCJ14A	TPSMCJ14CA	14	15.6	17.2	1	23.2	64.66	1	GEKA	BEKA
TPSMCJ15A	TPSMCJ15CA	15	16.7	18.5	1	24.4	61.48	1	GEMA	BEMA
TPSMCJ16A	TPSMCJ16CA	16	17.8	19.7	1	26	57.69	1	GEPA	BEPA
TPSMCJ17A	TPSMCJ17CA	17	18.9	20.9	1	27.6	54.35	1	GERA	BERA
TPSMCJ18A	TPSMCJ18CA	18	20	22.1	1	29.2	51.37	1	GETA	BETA
TPSMCJ19A	TPSMCJ19CA	19	21.1	23.3	1	30.8	48.73	1	GEBA	BEBA
TPSMCJ20A	TPSMCJ20CA	20	22.2	24.5	1	32.4	46.30	1	GEVA	BEVA
TPSMCJ22A	TPSMCJ22CA	22	24.4	26.9	1	35.5	42.25	1	GEXA	BEXA
TPSMCJ24A	TPSMCJ24CA	24	26.7	29.5	1	38.9	38.56	1	GEZA	BEZA
TPSMCJ26A	TPSMCJ26CA	26	28.9	31.9	1	42.1	35.63	1	GFEA	BFEA
TPSMCJ28A	TPSMCJ28CA	28	31.1	34.4	1	45.4	33.04	1	GFGA	BFGA
TPSMCJ30A	TPSMCJ30CA	30	33.3	36.8	1	48.4	30.99	1	GFKA	BFKA
TPSMCJ33A	TPSMCJ33CA	33	36.7	40.6	1	53.3	28.14	1	GFMA	BFMA
TPSMCJ36A	TPSMCJ36CA	36	40	44.2	1	58.1	25.82	1	GFPA	BFPA
TPSMCJ40A	TPSMCJ40CA	40	44.4	49.1	1	64.5	23.26	1	GFRA	BFRA
TPSMCJ43A	TPSMCJ43CA	43	47.8	52.8	1	69.4	21.61	1	GFTA	BFTA
TPSMCJ45A	TPSMCJ45CA	45	50	55.3	1	72.7	20.63	1	GFVA	BFVA
TPSMCJ48A	TPSMCJ48CA	48	53.3	58.9	1	77.4	19.38	1	GFXA	BFXA
TPSMCJ51A	TPSMCJ51CA	51	56.7	62.7	1	82.4	18.20	1	GFZA	BFZA
TPSMCJ54A	TPSMCJ54CA	54	60	66.3	1	87.1	17.22	1	GGEA	BGEA
TPSMCJ58A	TPSMCJ58CA	58	64.4	71.2	1	93.6	16.03	1	GGGA	BGGA
TPSMCJ60A	TPSMCJ60CA	60	66.7	73.7	1	96.8	15.50	1	GGKA	BGKA
TPSMCJ64A	TPSMCJ64CA	64	71.1	78.6	1	103	14.56	1	GGMA	BGMA
TPSMCJ70A	TPSMCJ70CA	70	77.8	86	1	113	13.27	1	GGPA	BGPA
TPSMCJ75A	TPSMCJ75CA	75	83.3	92.1	1	121	12.40	1	GGRA	BGRA
TPSMCJ78A	TPSMCJ78CA	78	86.7	95.8	1	126	11.90	1	GGTA	BGTA

Note: 1. Add suffix "C" or "CA" after part number to specify Bi-directional devices.

2. For bidirectional type having V_{RWM} of 10 volts and under, the I_R limit is doubled.

SMD Type 1500 W

Rate and Characteristic Curve ($T_A=25^\circ\text{C}$ unless otherwise noted)

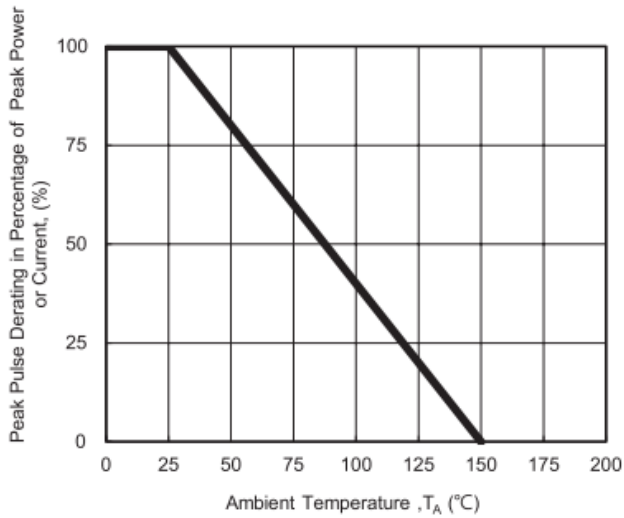

Fig. 1 - Pulse Derating Curve

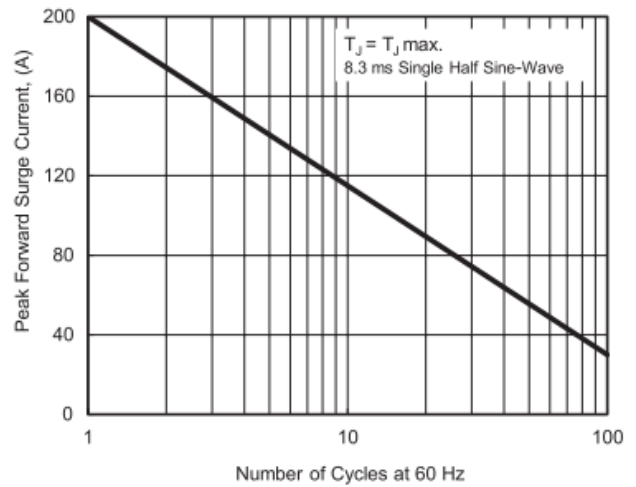

Fig. 2 - Maximum Non-Repetitive Surge Current

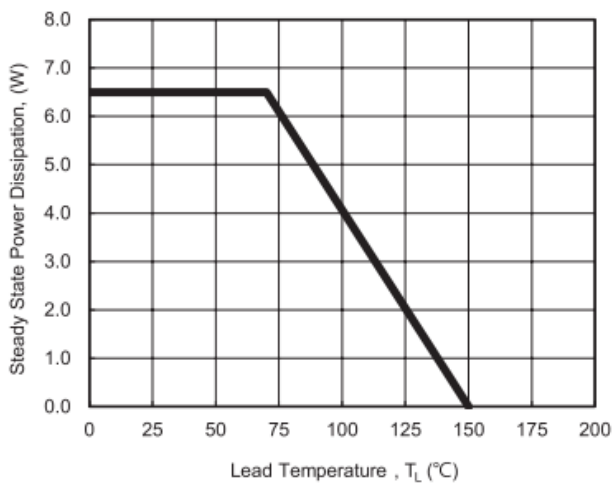

Fig. 3 - Steady State Power Derating Curve

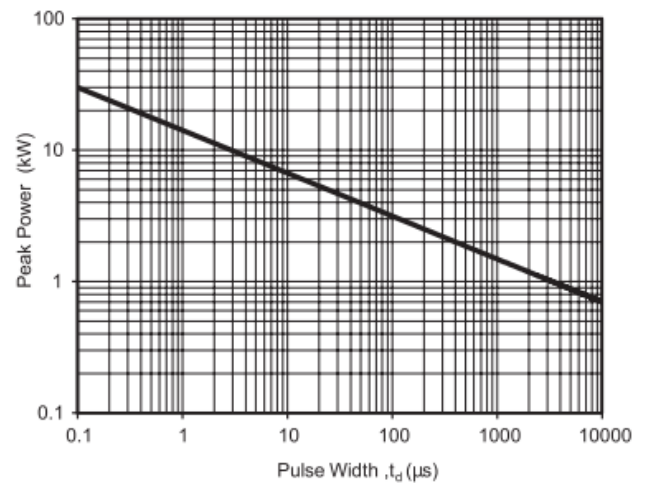

Fig. 4 - Peak Pulse Power Rating Curve

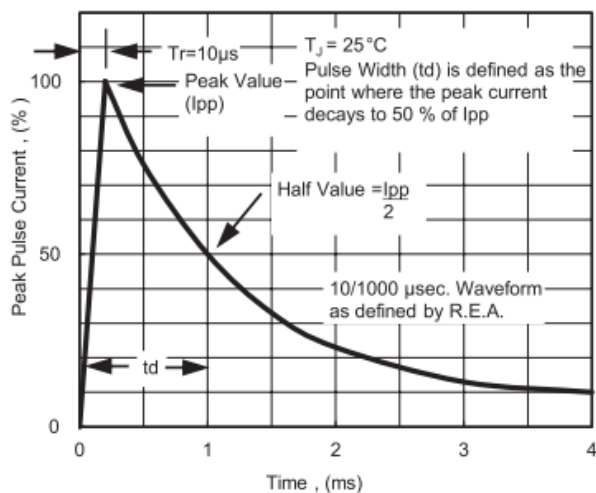

Fig. 5 - Pulse Waveform

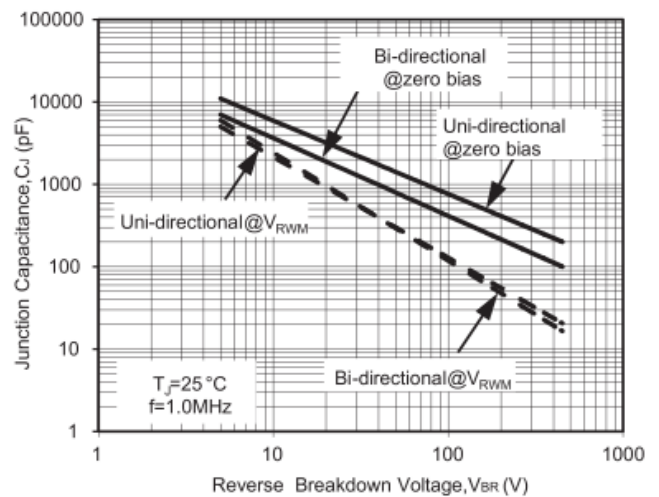

Fig. 6 - Typical Junction Capacitance

Transient Voltage Suppression Diodes: TPSMCJ Series

SMD Type 1500 W



IR-reflow soldering profile

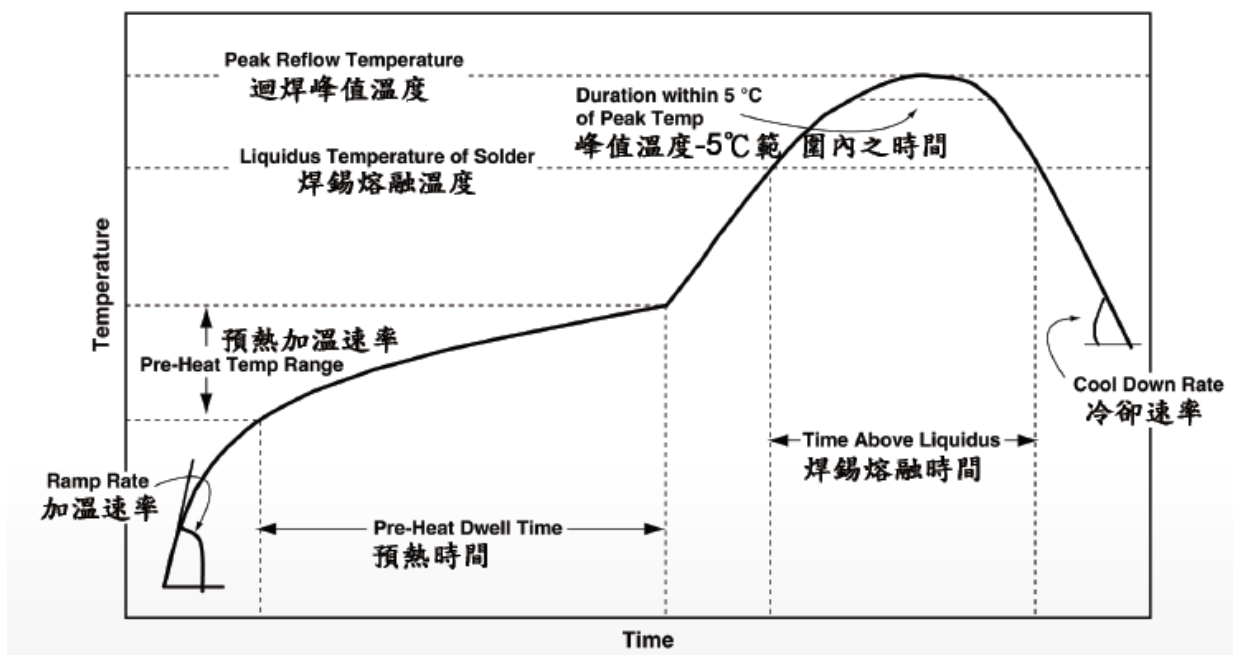

LEAD(Pb)-FREE SOLDER(SnAgCu) REFLOW PROFILE ATTRIBUTES	
PROFILE ATTRIBUTE	PROFILE ATTRIBUTE
Peak Reflow Temperature	250(+10/-5)°C
Time within 5°C of Peak Temperature	30s max
Liquidus Temperature of Solder	217°C
Cool Down Rate	6 °C/s max
Time above Liquidus	60s to 150s
Pre-heat Temperature Range	150°C to 200°C
Pre-heat Dwell Time	60s to 120s
Maximum Ramp Rate	3 °C/s max

Transient Voltage Suppression Diodes: TPSCMJ Series

SMD Type 1500 W



■ Packaging

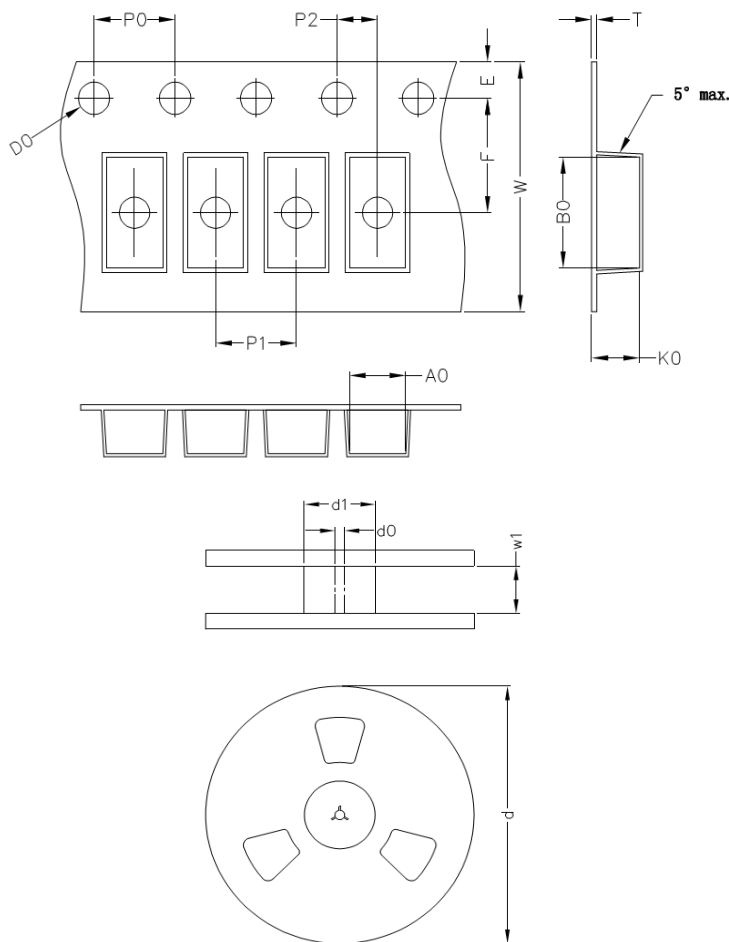

Item	Symbol	DO-214AB (SMC) Unit: mm
Carrier width	A0	6.05
Carrier length	B0	8.31
Carrier depth	K0	2.54
Sprocket hole	D0	1.55
Sprocket hole position	E	1.75
Punch hole position	F	7.5
Sprocket hole pitch	P0	4
Carrier pitch	P1	8
Embossment center	P2	2
Tape thickness	T	0.4
Tape width	W	16
Reel outside diameter	d (13")	330
Reel inner diameter	d1	50
Feed hole diameter	d0	13.50
Reel inner width	w1	18.4

Note: The tolerance of carrier tape and top cover is ± 0.1 mm, and the tolerance of reel is ± 2 mm

■ Quantity

MPQ: 3,000pcs

Package Type	Reel Size	Reel	Inner Box
	inch	Kpcs	Kpcs
DO-214AB	13	3	6

■ Warehouse Storage Conditions of product

- Storage Condition:
 - Storage Temperature: 15~30°C
 - Relative Humidity: $\leq 75\%$ RH
 - Keep away from corrosive atmosphere and sunlight.
- Period of Storage: 1 year.